

# Use Of Structure Maps To Facilitate Problem Solving In Algebra-Based Physics

Fran Mateycik<sup>1</sup>, David H. Jonassen<sup>2</sup> and N. Sanjay Rebello<sup>1</sup>

<sup>1</sup>*Department of Physics, 116 Cardwell Hall, Kansas State University, Manhattan, KS 66506-2601*

<sup>2</sup>*Department of Educational Psychology, 221C Townsend Hall, University of Missouri, Columbia, MO 65211*

**Abstract.** In this study we explore the use of expert-designed structure maps by students in an algebra-based physics course and the evolution of these maps based upon students' reactions and feedback collected over one semester. The participants were trained to use structure maps while solving problems sharing similar deep-structure elements. They met for one hour every week to work on the problems using the maps. We report here on the ways in which students used the structure maps during the interviews, the difficulties faced by students as they attempted to use these maps as well as the feedback offered by students regarding the maps. We also report on how we changed the maps based on feedback from the students and to facilitate their use during problem solving.

**Keywords:** problem solving, algebra-based physics, students' perceptions, physics education research, concept maps

**PACS:** 01.40.Fk

## INTRODUCTION

Problem solving is regarded as an important cognitive function for all manner of contexts, including Physics [1, 2]. Experts in problem solving are capable of establishing procedures for solving different types of problems, while overlooking any surface detail that might distract a novice student [3]. Research has also shown that students' use of concept maps across several methodological features and instructional conditions was associated with increased knowledge retention [4].

In this study, we instruct students to use expert-designed structure maps while problem solving for a semester long treatment in an introductory algebra-based physics course. Previous investigations have reported that over the long term students can acquire procedural automation of a strategy assimilating it into their problem-solving repertoire [5,6]. Our objective was to gauge how students react to expert-designed structure maps over the course of a semester and how the maps evolved to meet the needs expressed by the students. Here, we address the following questions:

- Q1) How do students use expert-designed structure maps to solve problems and what difficulties do they experience while using these maps?
- Q2) How do the maps evolve in response to students' feedback?

## LITERATURE REVIEW

A structure map is best described as a visual representation expressing functional interdependency between concepts and quantities [6, 7]. The structure maps for this project were created by two experts knowledgeable in physics education. Students were trained to use the structure map by marking quantities that are given in a problem, the quantity that is asked for in the problem and quantities that must be calculated in order to progress from the given quantities to those asked for in the problem. Figure. 1 shows an example of a structure map provided to students for problems related to Newton's II Law.

## METHODOLOGY

Twelve student volunteers enrolled in algebra-based physics were randomly selected from the original 46 volunteers. Two groups of six students were formed based upon student schedules. These 12 participants met in their respective groups a total of nine times during the semester and met with the moderator individually twice during the semester. The individual interviews were conducted at the mid and end points of the semester. One of the 12 volunteers selected dropped the class prior to the completion of the study.

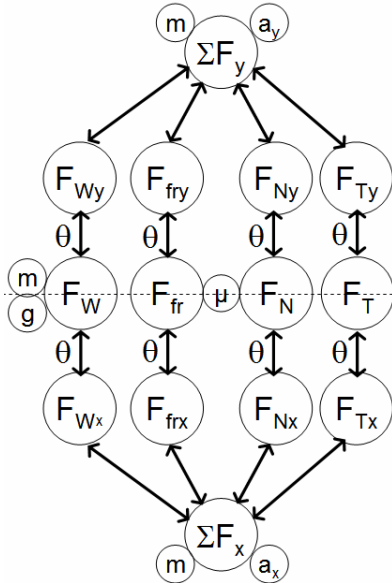

**FIGURE 1.** A structure map used during week 4. Problems selected for students to work on while using this map were variations of problems asked in Chapter 4 of *Physics: Principles with Applications*, Giancoli, 6<sup>th</sup> Edition.

The two groups of six students met each Friday for one hour. For the first two weeks of the semester, during these group interviews, a moderator would hand out a set of similar deep-structure problems for students to work on briefly and discuss the contrast between each of the problems. The selected problems were variations of problems asked in *Physics: Principles with Applications*, Giancoli, 6<sup>th</sup> Edition.

In the third week, students were introduced to structure maps for a given section of the textbook. (See Fig. 1 and Fig. 2 for examples of structure maps used in the first half of the semester)

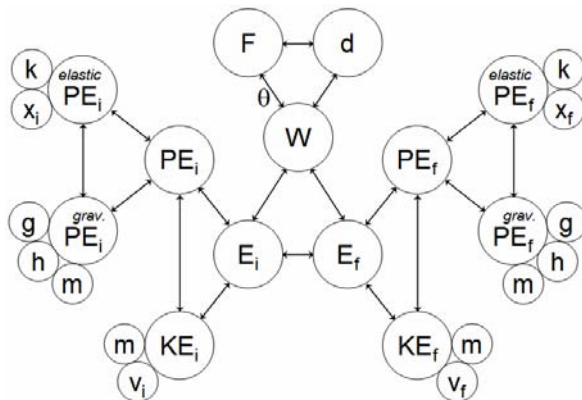
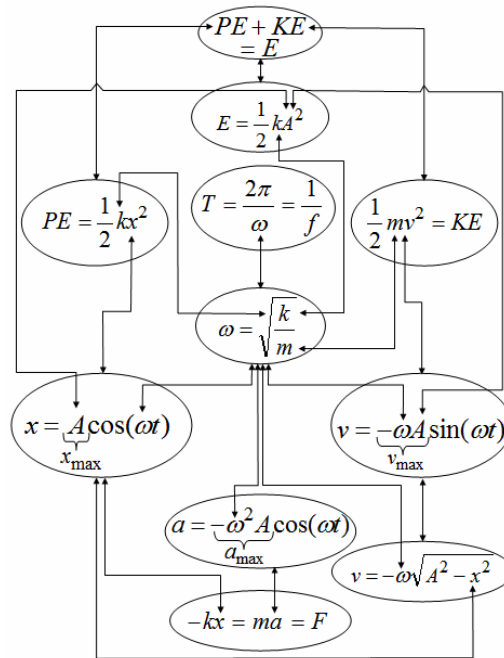

**FIGURE 2.** A structure map used during week 6. Problems selected for students to work on while using this map were variations of problems asked in Chapter 6 of *Physics: Principles with Applications*, Giancoli, 6<sup>th</sup> Edition.

Students were asked to use the structure maps as they saw fit while working out the problems handed out by the moderator. They were given time to use the

map in their own way and assistance was provided only when participants were unable to help one another. Students continued to discuss the similarities and differences between problems. Students were also asked to react to the structure maps and discuss elements of the map that they found useful.

For the remaining three weeks of group interviews, participants were again asked to use structure maps while solving problems, but the maps were restructured to accommodate some of the students' suggestions. Structure maps used for the rest of the semester became visual representations of equations and the relationships between quantities within equations for a given section of the textbook. (See Fig. 3 below for the map used during week 10).



**FIGURE 3.** A structure map used during week 9. Problems selected for students to work on while using this map were variations of problems asked in Chapter 11 of *Physics: Principles with Applications*, Giancoli, 6<sup>th</sup> Edition.

At the end of the group interviews, students were asked to explain how they felt about the new maps and discuss the features they found most useful.

## RESULTS & DISCUSSION

For the purposes of this report, results will focus on three group interviews. Each group interview selected was a point of substantial change in student feedback about the structure maps. These interviews were conducted on the fourth, sixth and ninth weeks of the semester. Participants were asked to solve four problems while using the expert-designed structure maps. To probe students' reactions and use of the

structure maps, each student was asked the same two questions at the end of each group interview and any necessary follow-up questions: *How did you like the map? How did you use the map?*

### Week 4

During week 4, the structure map shown in Fig. 1 was introduced to students covering dynamics and Newton's laws. Only one of the six students in group 1 stated they found the map useful. This student believed the map organized information from the problem statement so that connections between quantities could be readily seen.

*G1S2: "I do like the concept map because there are some equations involved in physics that it's just like, when you need that and how do you use it and why and kind of I don't know, just organizes it better so that you can look at what connects with what."*

One of the five students in the second group did not use the map while solving problems simply because he did not want to. Of the remaining four students only one felt the map was helpful while solving the problems. This student responded that it helped her keep track of the information given and information she was looking for.

Most students in both groups voiced a concern that the map was hard to follow. Some were more specific in stating that not all of the information needed could be displayed on the map while others agreed:

*G2S3: "I don't know how to mark it on here exactly. Like, I couldn't figure out how to relate like the terms on here to the problem."*

Two students, one from each group, also felt that the map was difficult to use without an equation sheet nearby. Most other students within both groups agreed with this claim as well.

### Week 6

During week 6, the structure map shown in Fig. 2 was introduced to students covering work and energy. The map's physical layout was similar to maps previously used, but because this map covered work and energy, there was a temporal symmetry to the map that was not previously available for other physics principles like kinematics or dynamics. The left side of the map contained all initial quantities and the right side contained all final quantities.

There was a significant difference in student feedback on this map compared to the previous map. All 11 students favored the work energy map over the previous kinematics and force maps, but only 10 of 11

used the map during the interviews. When we asked each student individually about their thoughts on the structure map, one student that did not use the map stated, *"I did not need it. Why would I use it?"* For future reference, I will refer to this student as G2S5.

Other participants were also asked to explain why they liked the work energy map over the previous map. A couple typical responses are below:

*G1S1: "I feel like this one you're just looking for your potential energy final, like I feel like it's just easier to focus in on that area [of the map] and how you would lead there, other than the other one that's just like you have [a quantity] down here but you feel like you have to go through all the other bubbles."*

*G2S4: "Like this (force map) it's all one big thing, but for this (work energy map) you can follow along so you can go from this to get this and ...like you can follow the arrows on this one."*

All other participants, with the exception of G2S5, used the map and found it easier to navigate between quantities that were given and those that were asked for in the problem. Some referred to the work energy map as being similar to a "road map". They were capable of selecting all values that were given in the problem by circling them and selecting the value that was asked for by crossing an 'X' through the value. They then established a clear path following arrows which led from the quantities given in the problem to those asked for in the problem. Though this map was much better received than previous maps, students still wanted equations, to be provided:

*G2S2: "Unless you know all the equations that they're suppose to be making, it's still a little confusing."*

Two students also stated that they would prefer to see units included with the maps.

*G1S3: "...units, like what the units should be, like knowing what each value should have for units, so I know when I do the problem I'm not missing that."*

### Week 9

The structure map (Fig. 3) covering vibration and waves was introduced in week 9,. The map contained equations in the nodes, while the arrows represented relationships between quantities within the equations. Initially the map was viewed as too complicated by some students in both groups.

*G2S3: "Well I felt like I needed it in problem two...I don't know, it's just a lot of arrows.... a lot more stuff I guess. It is intimidating"*

Three other students in group 1 and one student in group 2 used the map only to look up equations. Two students in group 1 and one student in group 2 used the arrows between quantities to guide them to a solution.

As the session progressed, all 11 students liked the new map and found it to be useful while solving problems. Most students liked having the equations given directly on the map. Many felt that the arrows connecting quantities across equations was very helpful. :

G1S3: “[This map is] a lot easier to use. I don’t have to like look up a bunch of different equations like, oh I don’t have that... you can just see how everything relates and what you have and how it works together.”

Similarly, G2S3 no longer felt the map was intimidating, deciding that no arrows linking two equations with quantities using similar notation was a good indication that those were not identical values. G2S5 also decided that he liked the map and used it for problem 4, but generally did not prefer using any map. Here is a small segment of the group 2 interview:

I: “What did you think of the map after problem 4?”

G2S2: “I like it.”

G2S5: “Yeah.”

G2S3: “Used it a lot. It’s nice.”

G2S2: “I might actually be putting it on my cheat sheet for the test.”

I: “What was it that you liked about it?”

G2S2: “It’s easy to understand.”

I: “Okay. Were the arrows helpful?”

G2S3: “Yeah because if you didn’t know what you were doing to an extent, but you know kinda what you’re doing, you could be like this problem it (v) doesn’t link to this (vmax) because your arrow isn’t there. I kinda looked at it that way.”

G2S5: “This is good, but can I say my personal opinion?”

I: “Of course.”

G2S5: “I prefer to work without maps. Like if you know the equation, you know the variables, then there’s no need to see this thing, like that’s my...I don’t know.”

The transcript above indicates that almost all students reacted positively to this final version of the structure map. They were able to use it both as an equation sheet as well as a roadmap to solve problems.

## CONCLUSIONS

We address each of our research questions below:

Q1) How do students use expert-designed structure maps to solve problems and what difficulties do they experience while using these maps?

Our results indicate that students have trouble using the quantities in a structure map to solve problems if they are not provided explicit equations. Students appear to like the map in Fig. 2, but we do not know whether it was the map’s temporal symmetry or a material that is just better understood by this student population. It appears that a map with equations in the nodes (e.g. Fig. 3) facilitates students’ recognition of connections between individual quantities inside equations and thereby facilitates problem solving..

Q2) How do the maps evolve in response to students’ feedback?

Based on feedback from students, we changed the structure maps from one session to another to better meet students’ perceived needs. The structure maps evolved from those in which the nodes contained physical quantities to those in which the nodes contained complete equations, with arrows showing how quantities between equations were related. This map provided students a pathway to connect the equations and appeared to facilitate problem solving.

## LIMITATIONS & FUTURE WORK

Due to the limited duration of the study and lack of direct assessment of problem solving, we cannot ascertain whether the use of structure maps facilitates students’ problem solving. Future work would need a larger experimental sample and the impact of structure maps on problem solving would need to be directly assessed. From this study it appears maps that incorporate equations in their nodes would be the best candidates for future studies in this area.

## ACKNOWLEDGMENTS

This research is supported in part by NSF grant DUE-06185459. Opinions expressed are those of the authors and not necessarily those of the Foundation.

## REFERENCES

1. L. Hsu, et al., *American Journal of Physics* **72**(9), 1147-1156 (2004).
2. D.H. Jonassen, *Educational Technology and Research and Development* **48**(4), 63-85 (2000).
3. M.T.H. Chi, et al., *Cognitive Science* **5**(2), 121-152 (1981).
4. J. C Nesbit and O.O. Adescope, *Review of Educational Research* **76**(3), 413-448 (2006).
5. K.A. Ericsson, R.T. Krampe, and C. Tesch-Romer, *Psychological Review* **100**(3), 363-406 (1993).
6. J.D. Novak, B.D. Gowin, and G.T. Johansen, *Science Education* **67**(5), 625-645 (1983).
7. D. Gentner, *Cognitive Science* **7**(2), 155-170 (1983).